



————— Electrical Service Requirements —————

RESIDENTIAL SERVICE

UNDERGROUND



TABLE OF CONTENTS

GENERAL.....	Page 3
TRENCHING – SECONDARY (120/240 volts)	Page 3
CONDUITS FOR PUD-INSTALLED CONDUCTORS	Page 5
PUD OR CUSTOMER-INSTALLED SECONDARY SERVICE WIRE (120/240 volts)	Page 7
RESIDENTIAL SERVICE EQUIPMENT	Page 8
METER PEDESTAL - 200 AMP SERVICE.....	Page 14
METER PEDESTAL - 400 AMP SELF-CONTAINED & 400 AMP CT RATED	Page 16
CONVERSIONS, OVERHEAD TO UNDERGROUND.....	Page 20
PRIMARY SERVICE (7200 Volts) - RESIDENTIAL SYSTEMS ON PRIVATE PROPERTY	Page 22

GENERAL

1. Availability and location of PUD facilities for providing underground service shall be determined at the PUD's office before proceeding with the wiring. Site Plans, Legal Description and New Service Application shall be submitted to the PUD as much in advance as possible prior to any construction.
2. The PUD will design, install, own and maintain the complete primary underground electric distribution system and all associated residential secondary distribution.
3. Underground service installation requiring a special voltage or road boring will require individual consideration for feasibility and charges required.
4. Required permits and easements will be obtained prior to construction. Please respond to easement request immediately when contacted by the PUD's Real Estate Department. This will help ensure that your project will not be delayed.
5. It is the customer's responsibility to contact appropriate gas, cable, phone companies, and any other utilities needed to arrange for their installation.
6. For questions or clarifications, contact a PUD Area Designer. Electrical Service Requirements (ESR) and ESR Bulletins supercede any information in this handout.

TRENCHING - SECONDARY (120/240 volts)

1. In general, all trenching, backfilling and restoration work on private property shall be done by the customer.
2. The minimum cover required for secondary (0 - 600V) shall be 24 inches. Refer to Figures 4-1 and 4-2.
3. The minimum horizontal and vertical separation between electric and gas shall be 12 inches. The gas line shall be staked or shaded with backfill every 10 feet or as required to maintain separation. The minimum separation between electric and water or sewer shall be 36" horizontal and 12" vertical at crossings. Refer to Figure 4-1.
4. Backfill containing large rock or paving material, cinders, large or sharply angular substance, or corrosive material shall not be placed in an excavation where materials may damage conduits, cables or other substructures or prevent adequate compaction of fill or contribute to corrosion of conduits, cables or other substructures (NEC 300-5).
5. The customer shall prepare a work area at the metering point to allow the service conductors to be safely installed by the PUD. **Continuous secondary service conduit** shall stop 3 feet from the point of service (pedestal or pole) as provided by the PUD. The formed deep socket coupling (large flared end) of the conduit may be pointed in either direction. A bellend shall not be installed on the end of the conduit; however, a tapered, manufactured poly conduit plug shall be installed on each open end to keep out dirt and foreign objects prior to the PUD installing the conductors.

Refer to Figure 4-2 (Conduit Extensions). The customer shall prepare a work area 5 feet x 5 feet minimum centered around the meter base, backfilled and compacted to within 4 inches of final grade and clear of obstructions. The meter socket and riser shall be secured to the building studs or other structural members to provide a solid base for cable pulling. Refer to Figures 4-4 through 4-7.

- The maximum continuous service conduit run shall be 250 feet in length, from the meter base to the point of service. **Contact a PUD Area Designer prior to installation.**

Note: The PUD must inspect and approve all conduit installations prior to backfilling.

Minimum Clearances from PUD Underground Lines in Conduit

Type of Utility Line	Vertical Separation (Crossings)			Horizontal Separation		
	Electric Primary	Electric Secondary Main	Electric Secondary Service (300V Max.)	Electric Primary	Electric Secondary Main	Electric Secondary Service (300V Max.)
Communication	6"	6"	6"	0"	0"	0"
Communication Service	3"	3"	3"	0"	0"	0"
High Pressure Gas	12"	12"	12"	36" (60" Preferred)	36" (60" Preferred)	36" (60" Preferred)
Low Pressure Gas	6"	6"	6"	12"	12"	12"
Gas Service	6"	6"	6"	12"	12"	12"
Sewer Main & Lateral	12"	12"	12"	36" (60" Preferred)	36" (60" Preferred)	36" (60" Preferred)
Sewer Service	12"	12"	6"	36"	36"	12"
Water Main & Lateral	12"	12"	12"	36" (60" Preferred)	36" (60" Preferred)	36" (60" Preferred)
Water Service	12"	12"	6"	36"	36"	12"
Storm & Roof Drains	12"	12"	6"	36" (60" Preferred)	36" (60" Preferred)	36" (60" Preferred)
Lighting & Electric Supply	6"	6"	6"	0"	0"	0"

Secondary Distribution Trench With Joint Utilities

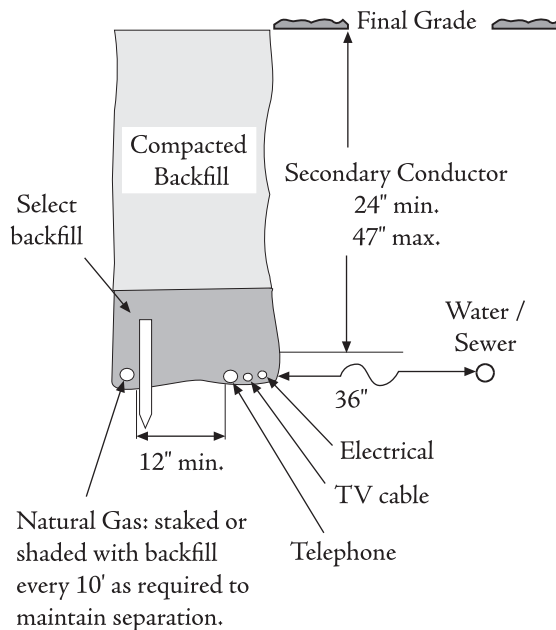

Figure 4-1

CONDUITS FOR PUD-INSTALLED CONDUCTORS

1. All Non-metallic conduit must meet the following requirements
 - a. The following information shall be imprinted on all PVC conduit:
 1. Manufacturer's name or trademark
 2. Nominal size
 3. Material (PVC)
 4. Utility duct and Standards (specification) number
 - b. 2", 2½" and 3" shall be gray and meet or exceed the requirements of any one of the following standards:
 1. NEMA TC-2 (Schedule 40 or 80)
 - c. Schedule 40 or 80 PVC is required for service riser according to the NEC 300-5d. and NEMA Standard TC-2 for applications listed below:
 1. Type III - Designed for normal-duty applications above ground (Sch 40)
 2. Type IV - Designed for heavy-duty applications above ground (Sch 80) (Hazardous areas, e.g., next to driveways).
 - d. All conduit bends shall be long radius type.

<u>Conduit Diameter</u>	<u>Minimum Radius</u>
2", 2½", 3"	24"

PVC conduit shall not be mechanically heated to form any sweep (bend).
 - e. Each PVC conduit joint must be permanently assembled using a PVC solvent cement appropriate for the application.
2. Secondary Conduit Requirements
 - a. The conduit size for a 200 amp residential service riser shall be a minimum of 3 inches for 4/0 - 2/0 triplex.
 - b. The conduit size for a 201 - 400 amp residential service riser shall be a minimum of 3 inches for 350 kcm -4/0 triplex.
 - c. Secondary conduit shall be allowed a maximum total aggregate of 270° of bends, including the riser. All bends shall be long radius type (24-inch minimum).
 - d. A tapered, manufactured poly conduit plug shall be installed on all conduit ends to seal exposed ends of conduits to keep out dirt and foreign objects prior to the PUD installing the conductors. **(Do not use duct tape.)**
 - e. A continuous length of knot-free ¼-inch polypropylene pull rope or Herculine P125OW ½" polyester pull tape shall be installed by the customer with a 2-foot tail at each end for all secondary conduit(s), including future conduits, regardless of length of run.
 - f. The lower end of all service entrance conduits shall be turned so that they face towards the PUD's facilities (the source of the customer's service).

Figure 4-2: Secondary Trench

TRENCHING DETAIL

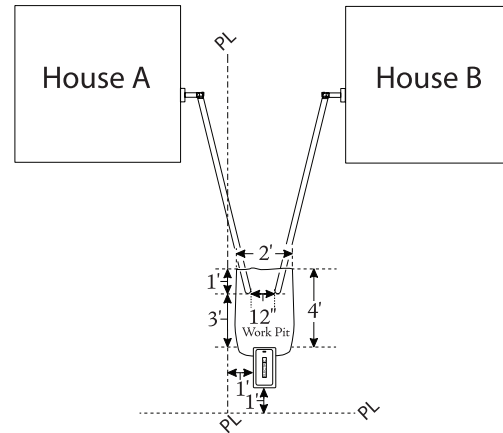
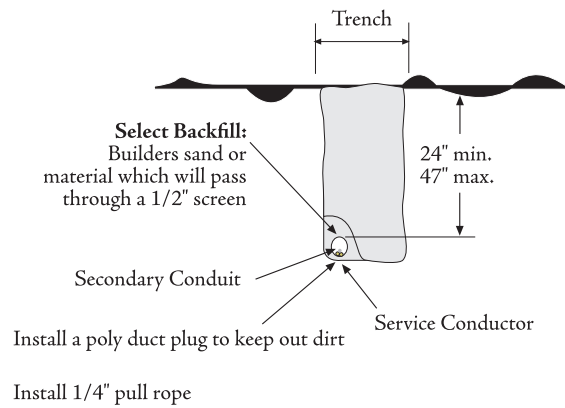
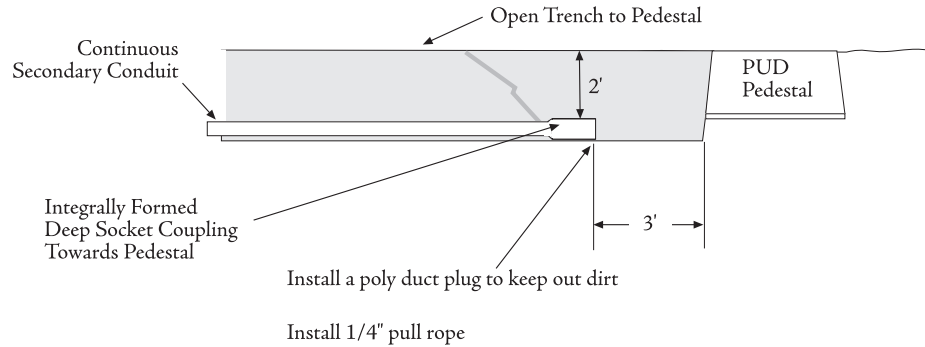

- PVC to stop 3' short of the pedestal.
- 2'x4' work pit to be dug out by customer, leaving 1' of PVC exposed.
- Must be 1' of separation between electrical conduit PVC's.

CONDUIT EXTENSIONS

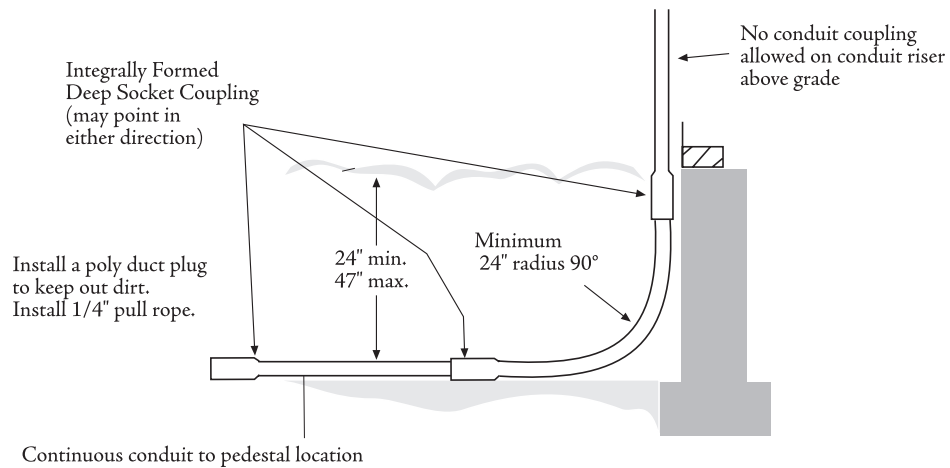

PUD OR CUSTOMER-INSTALLED SECONDARY SERVICE WIRE (120/240 volts)

1. There is a fee for the PUD supplied and installed secondary service cable installation, for up to 100 ft of cable. Over 100 ft is charged on a per-foot basis. (Contact your PUD Area Designer for the current fee for this service.)

2. The customer has the option of supplying and installing the secondary service cable.
 - PUD Area Designer will specify service termination locations for the meter and PUD connection point.

 - PUD Area Designer will specify cable size. Acceptable wire sizes include:
 - 200 amp 4/0 - 4/0 - 2/0 aluminum URD triplex XLPE USE-2
 - 400 amp 350kCM - 350kCM - 4/0 aluminum URD triplex XLPE USE-2Verify wire size with the appropriate PUD Designer prior to installation.

 - Customer will supply and install approved cable with a qualified installer, leaving an adequate excess length of service cable (5') at the PUD source connection point.

 - The customer will provide trenching and backfilling.

 - Approved conduit will be supplied and installed by the customer.

 - A scheduled **PUD inspection and approval is required prior to backfilling** conduit.

 - The customer will provide connection at the meter socket. Connections shall be made providing excess conductor as illustrated in Figure 4-3.

 - Connection at the PUD source will be provided by PUD.

 - A PUD inspection/connection fee for this option is required. (Contact your PUD Area Designer for the current fee for this service.)
 - PUD Engineering / Inspection fee includes a maximum of two site visits.
 - PUD connection fee covers the service connection of the customer's conductor to the existing available PUD facilities.

RESIDENTIAL SERVICE EQUIPMENT

1. A meter socket with a minimum capacity of 125 amps is required. Sockets shall be listed for use with aluminum/copper conductors. Typically a 200-amp socket is used, refer to Figure 4-3. A 200-amp socket is designed to accommodate size 4/0 conductor. The customer's wiring entrance into the meter socket shall be offset from the PUD's so as not to physically block the source lugs. An oxide inhibitor is required on stranded aluminum conductors of #8 awg or larger for terminal connectors (State of Washington Electric Code requirements).

Note: Meter socket may be surface mount or flush mount.

Figure 4-3: 200 Amp Meter Base

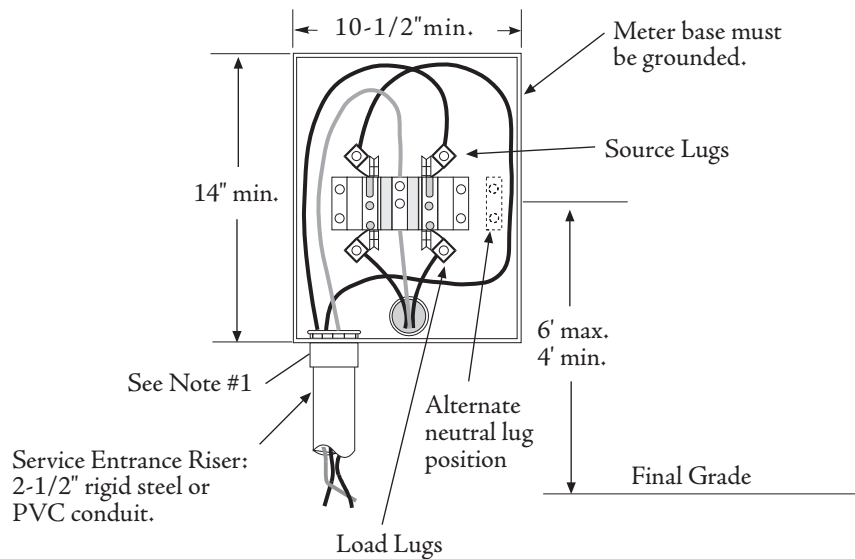

- Notes:**
1. Requires double lock nuts and protective bushing on rigid steel conduit. PVC plastic conduit requires threaded terminal coupling, one lock nut and protective bushing.
 2. Underground service sockets must have a minimum enclosure depth of four inches (4").

2. The standard 200-amp service entrance conduit shall be a minimum of 2½ inch. Service entrance conduits with a 90° bend shall terminate 24 inches minimum below the final earth grade measured to the top of the conduit (NEC 710-4.b). The lower end of all service entrance conduits shall be turned so that they face towards the PUD's facilities (the source of the customer's service).

3. Secure riser conduit with galvanized pipe straps and lag bolts, a maximum 5-foot spacing.
 - a. Schedule 40 PVC required for normal-duty applications above ground.
 - b. Schedule 80 PVC required for heavy-duty applications above ground. (Hazardous areas, e.g. next to driveways).
4. Service riser conduit shall not enter at the center of the bottom of the meter-base but shall be offset to one side.
5. Conduit couplings are not allowed on an underground service riser (above final grade). Exception: A formed deep socket coupling may be used on the service riser provided that it is a manufactured integral part of the conduit and it shall be oriented pointed away from the meter socket, towards the source. Refer to Figure 4-2.
6. Install ground per NEC Requirements.

Figure 4-4: 200 Amp Service, Riser 2.5" Minimum, Continuous Riser Style

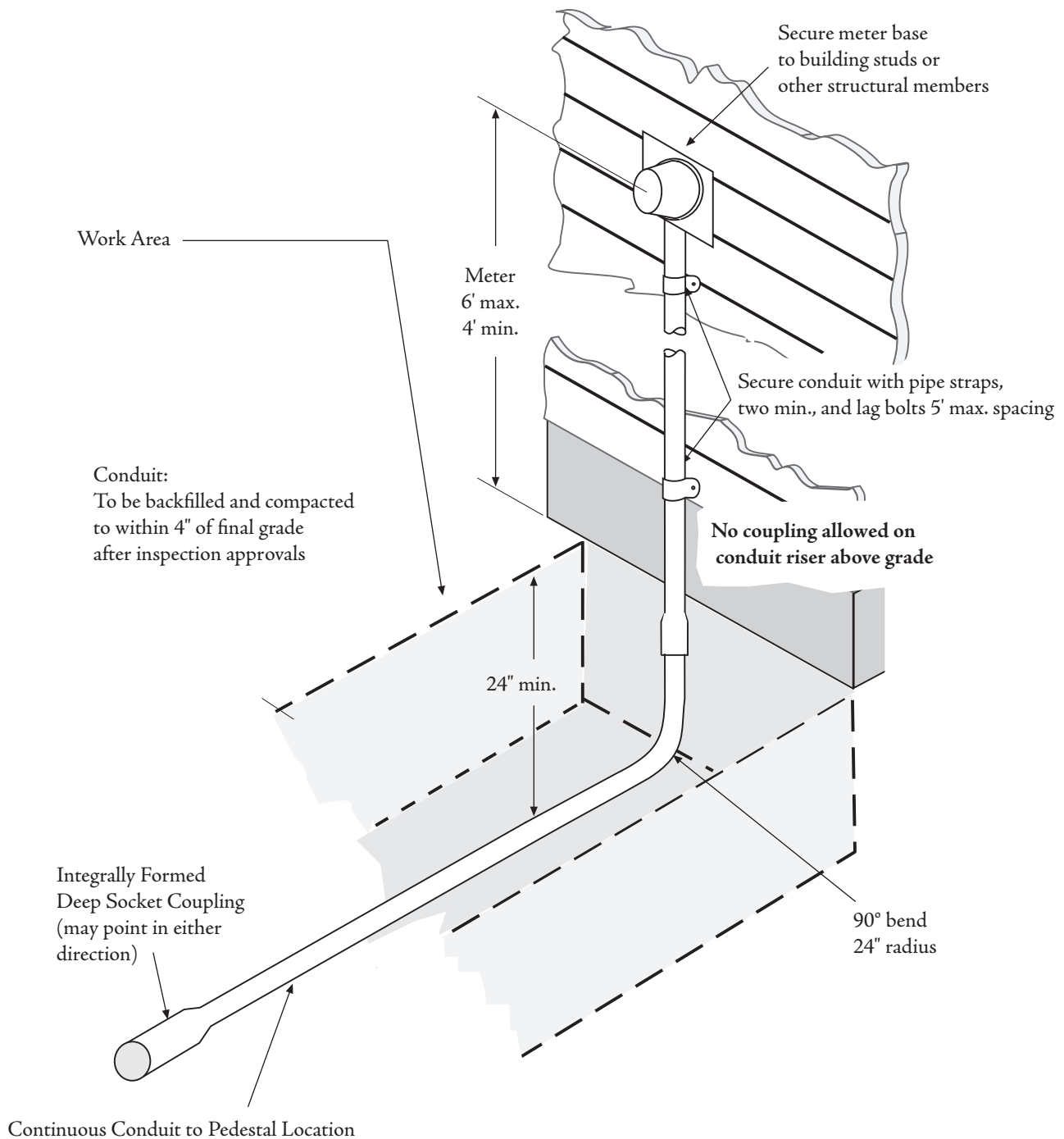

Install a poly duct plug to keep out dirt.
Install 1/4" pull rope.

Figure 4-5: 201 - 400 Amp Self-contained Meter Socket Service, Riser 3" Minimum

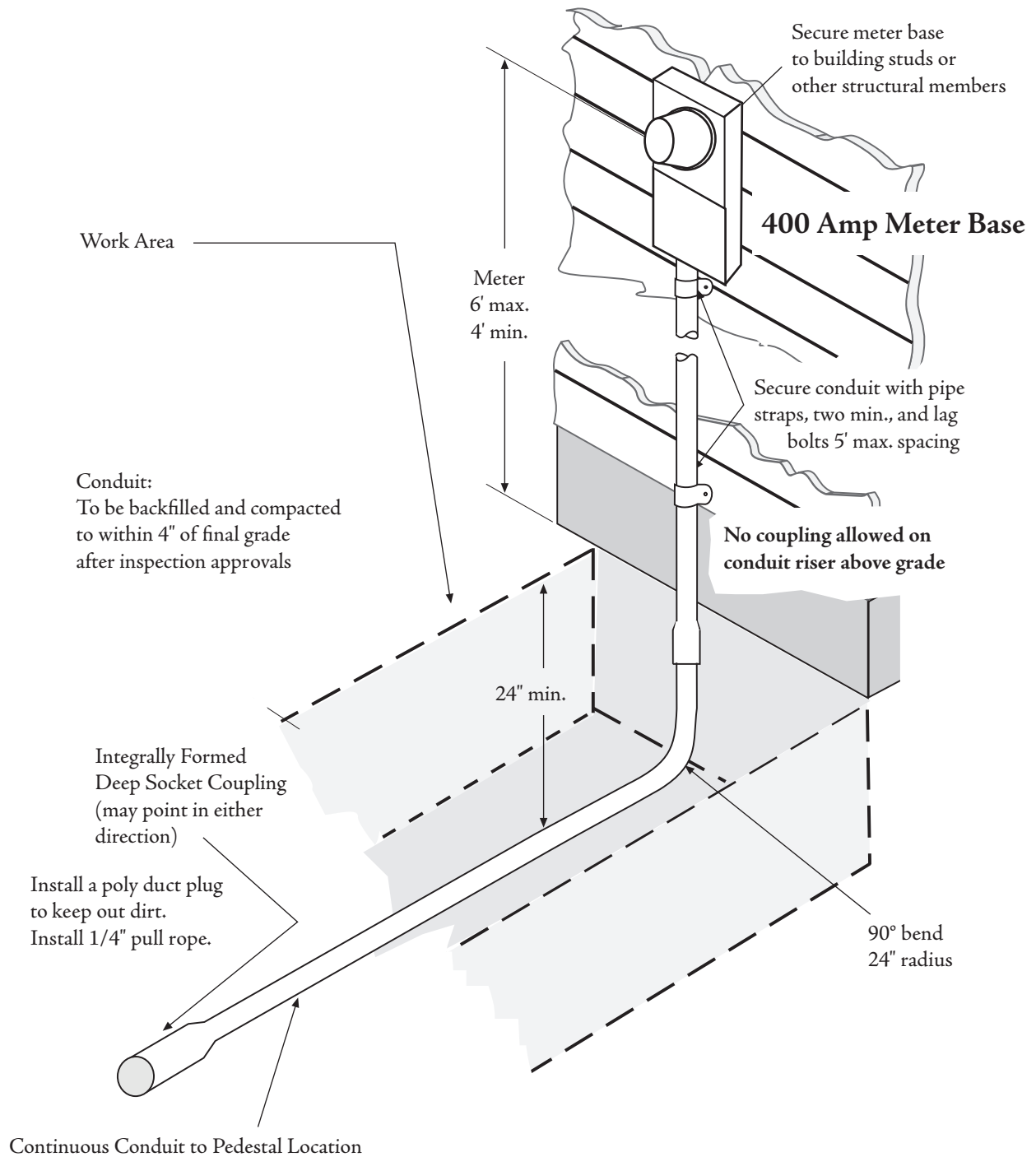

Figure 4-6: 201 - 400 Amp (CT Enclosure) Service, Riser 3" Minimum

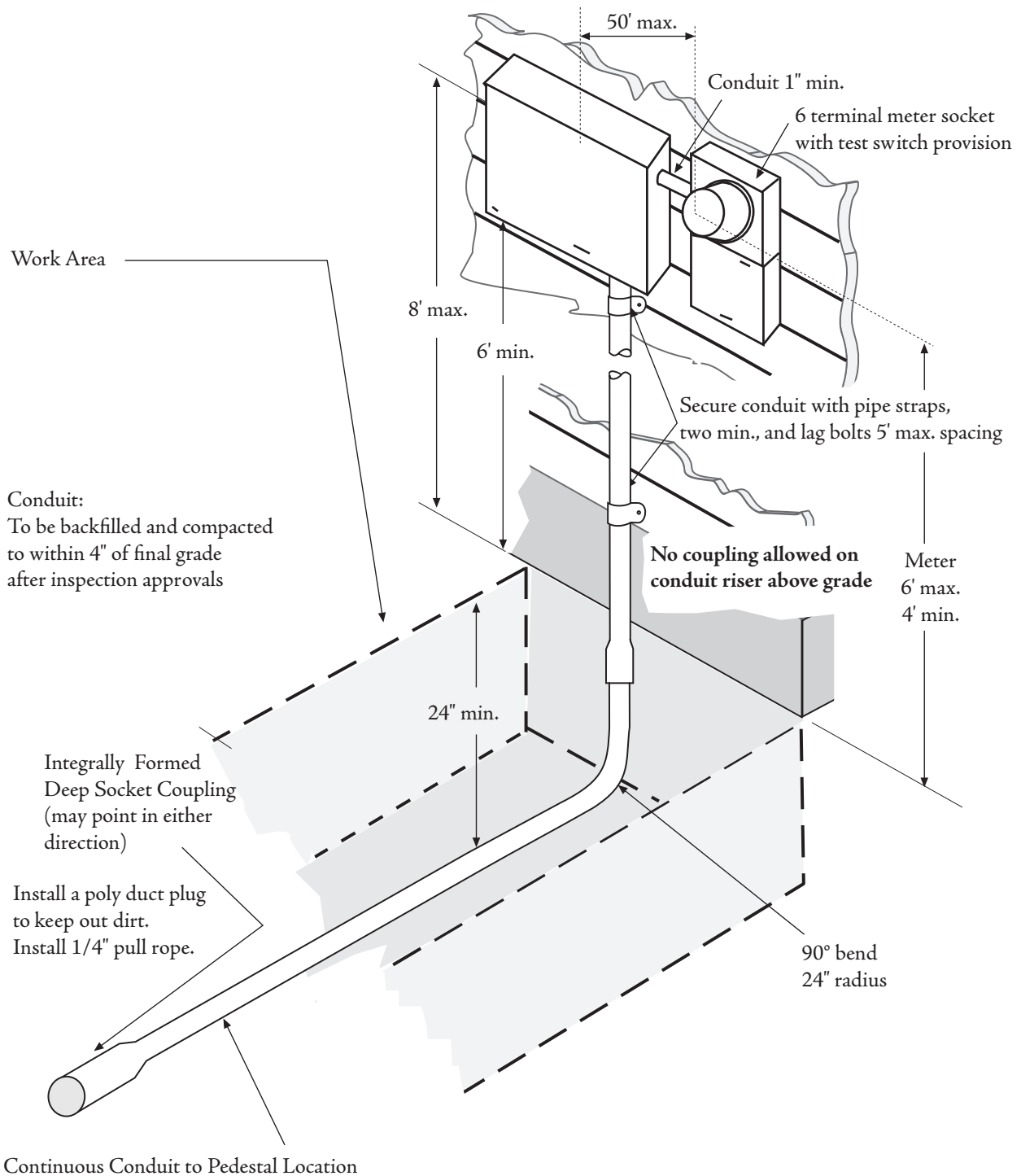
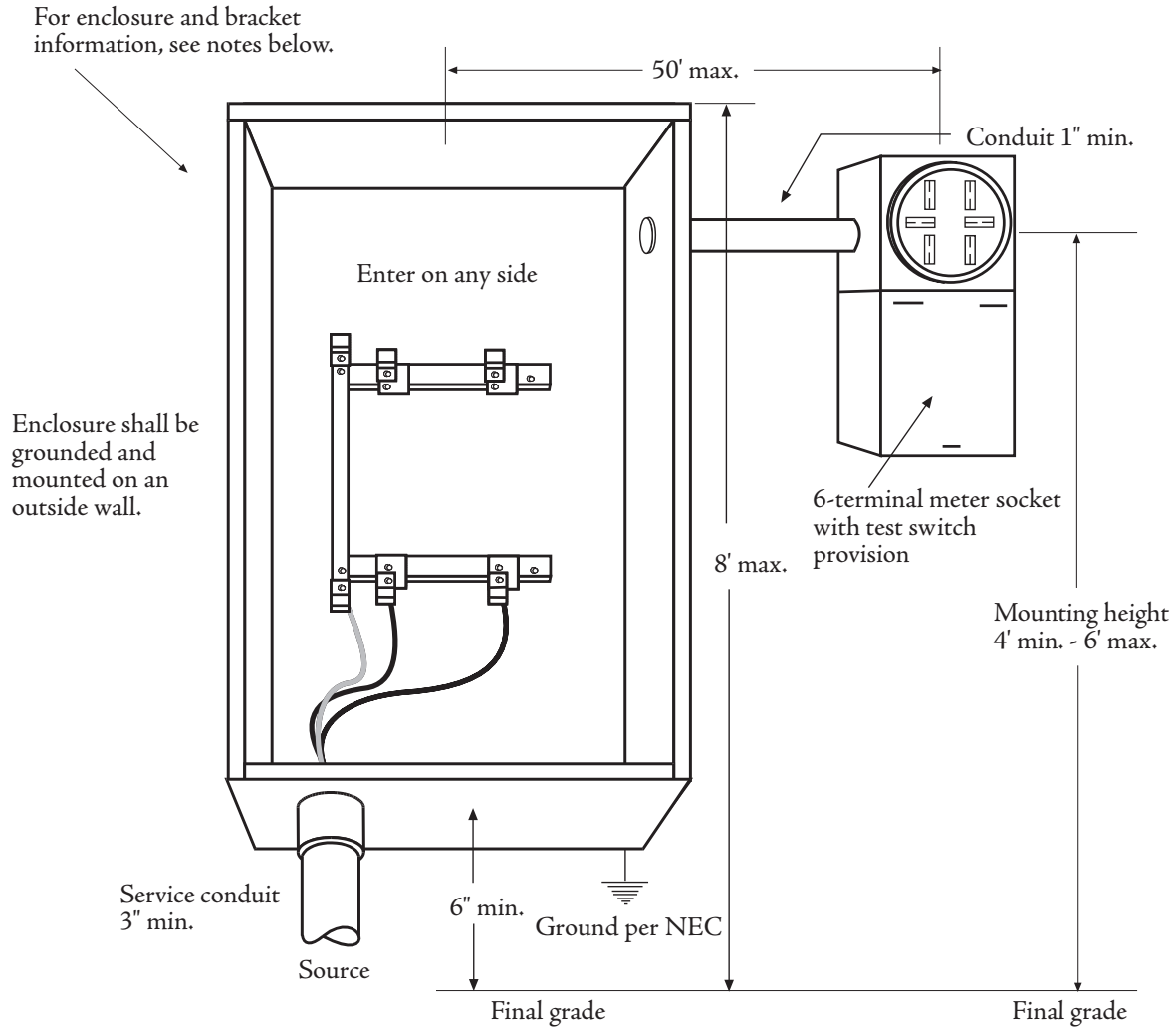

Figure 4-7: 201 - 400 Amp (CT Enclosure) Service - DETAIL



NOTES:

PUD will furnish, install and wire the current transformers. The PUD will also make metering connection and final service connection.

For single-phase units, the cabinet shall be 24" x 36" x 11" minimum. Refer to NEC for additional requirements.

Pre-fabricated brackets required for terminating conductors and mounting current transformers shall be specified in 328A of the EUSERC Manual. Refer to Figure 5-20.

Landing pads shall be rated at 50,000 amps.

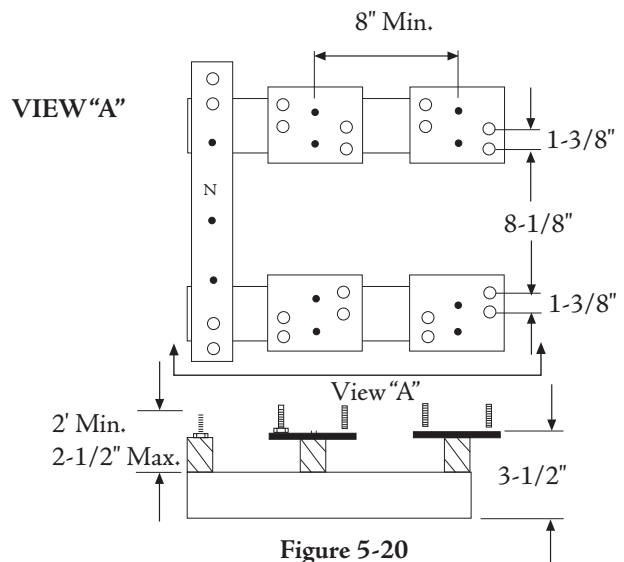

EUSERC DWG. NO. 328A

METER PEDESTAL - 200 AMP SERVICE

1. A factory assembled pedestal must be listed and approved or PUD approved and accepted. It must be set a minimum of 2 feet in the ground with a concrete pad of 2 feet x 2 feet x 3½ inches poured in place around the pedestal for support. The customer shall backfill, compact and install the concrete pad after inspection and prior to service installation. Refer to Fig 4-8, Exhibit A.
2. An on-the-job assembled meter pedestal, which is composed of listed or approved meter socket and conduit or raceways, must be supported by one of several methods. The preferred installation is by using two pieces of Unistrut channel embedded in a 12" diameter poured concrete footing 36" deep. Minimum Unistrut channel acceptable shall be hot dip galvanized 12 gauge steel 1½" x 1½", or PUD-approved equivalent. Also acceptable is using two pieces of 2" hot dip galvanized steel angle iron or 2" hot dip galvanized rigid steel pipe with a 2" hot dip galvanized steel cap embedded in a 12" diameter poured concrete footing 36" deep. The customer shall install the poured concrete footing, backfill and compact prior to inspection and service installation. The concrete footing should not encase the service riser conduits. Alternately, the PUD will accept a fully pressure treated 6" x 6" x 10' wood post set a minimum of 36" deep; however, it is the least desired method since it may not last as long as the other methods. *The wood post shall not be encased in concrete, but shall be backfilled with gravel to facilitate drainage.* Refer to Fig 4-8, Exhibit B.
3. The conduit shall be 2½ inch minimum.

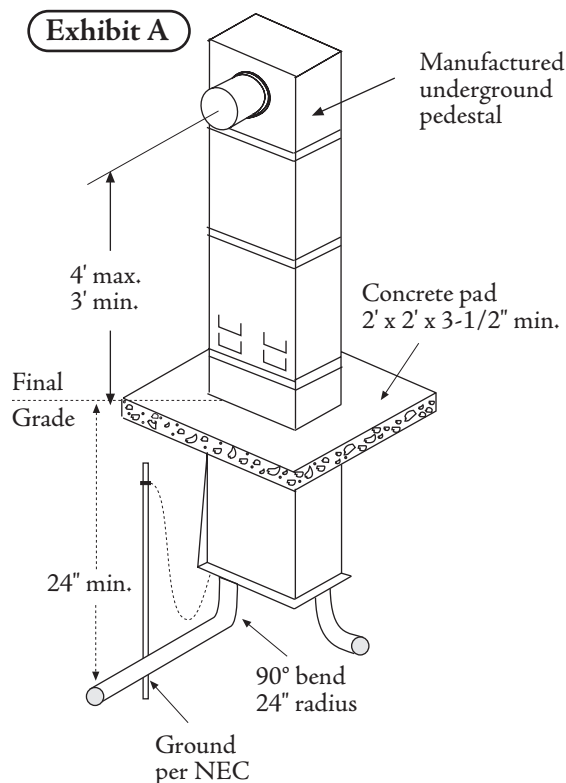

Figure 4-8, Exhibit A

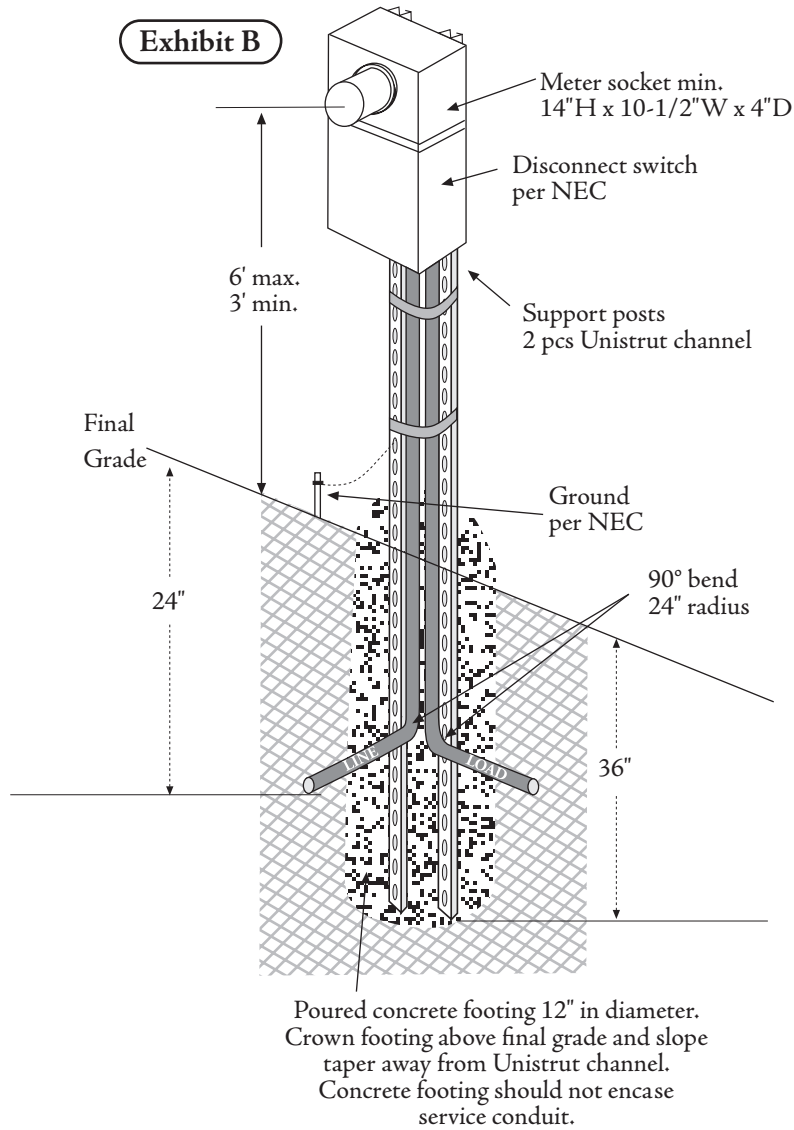

Figure 4-8, Exhibit B

METER PEDESTAL - 400 AMP SELF-CONTAINED & 400 AMP CT RATED

1. An on-the-job assembled meter pedestal, which is composed of listed or approved meter socket and conduit or raceways, must be supported by one of several methods. The preferred installation is by using two pieces of Unistrut channel embedded in a 12" diameter poured concrete footing 36" deep. Minimum Unistrut channel acceptable shall be hot dip galvanized 12 gauge steel 1 $\frac{5}{8}$ " x 1 $\frac{5}{8}$ ", or PUD-approved equivalent. Also acceptable is using two pieces of 2" hot dip galvanized steel angle iron or 2" hot dip galvanized rigid steel pipe with a 2" hot dip galvanized steel cap embedded in a 12" diameter poured concrete footing 36" deep. If needed, a minimum of $\frac{3}{4}$ " exterior grade plywood backing should be attached between the footings to support the equipment. The customer shall install the poured concrete footing, backfill and compact prior to inspection and service installation. The concrete footing should not encase the service riser conduits. Alternately, the PUD will accept a fully pressure treated 6" x 6" x 10' wood post set a minimum of 36" deep; however, it is the least desired method since it may not last as long as the other methods. *The wood post shall not be encased in concrete, but shall be backfilled with gravel to facilitate drainage. Refer to Fig. 4-8, Exhibit C; Fig. 4-9 and Fig. 4-10.*
2. The conduit shall be 3-inch minimum.

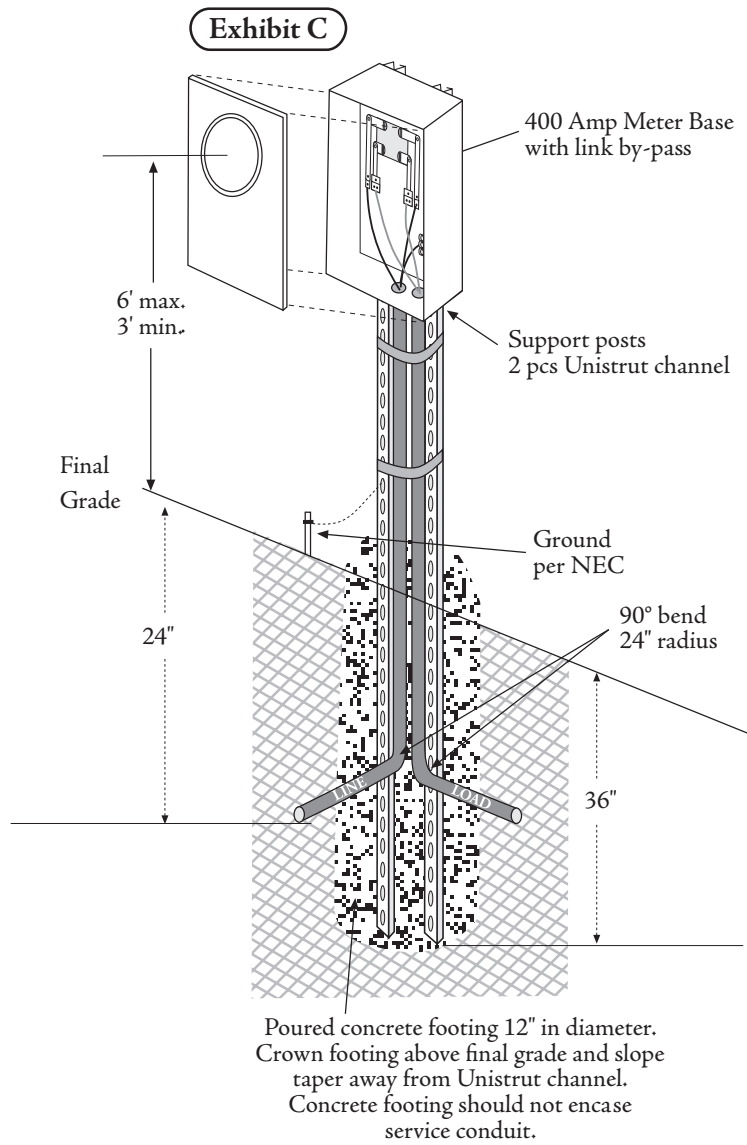

Figure 4-8, Exhibit C

Figure 4-9: Typical Meter Pedestal for 201-400 Amp Self-Contained Meter Socket for Use With a Class 320 Meter, Riser 3" Minimum

Preferred Construction:

Bolt service entrance equipment to *Unistrut channels with two pieces of *Unistrut crossmembers, two 2" x 6" fully pressure treated crossbeams or 3/4" min. exterior grade plywood. Extend each *Unistrut leg 36" min. below grade and embed each leg in a 12" diameter poured concrete footing. The concrete should not encase the service entrance conduit.

*Minimum Unistrut channel acceptable shall be hot dip galvanized 12 gauge steel 1-5/8" x 1-5/8" or District-approved equipment.

Alternate Construction:

2" hot dip galvanized steel angle iron or 2" hot dip galvanized rigid steel pipe with a hot dip galvanized pipe cap embedded in a 12" diameter poured concrete footing, or two fully pressure treated 6" x 6" x 10' wood post set 36" min. below grade and backfilled with gravel to facilitate drainage.

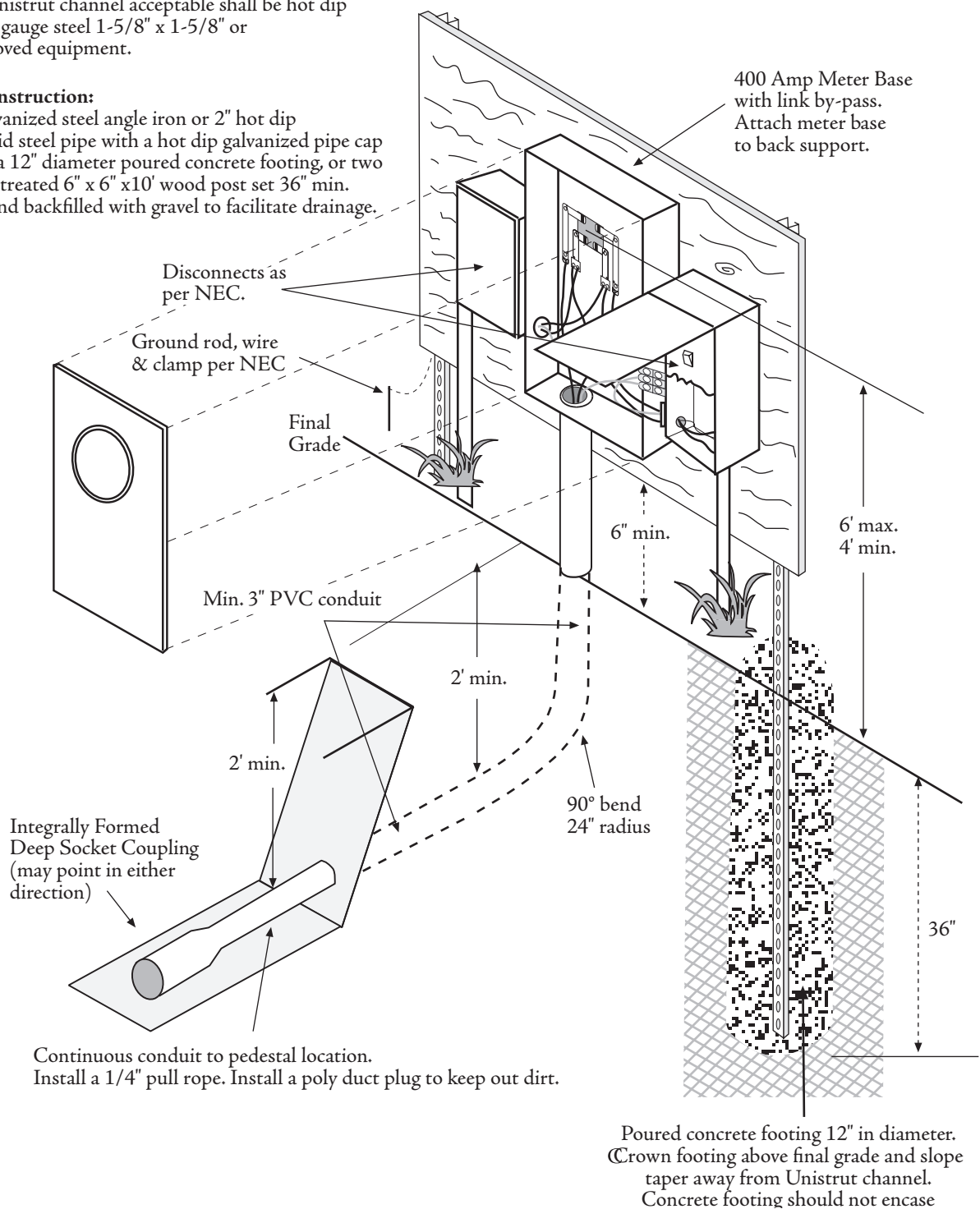

Figure 4-10: Typical Meter Pedestal for a 201-400 Amp Current Transformer Enclosure Installation, Riser 3" Minimum

Preferred Construction:

Bolt service entrance equipment to *Unistrut channels with two pieces of *Unistrut crossmembers, two 2" x 6" fully pressure treated crossbeams or 3/4" min. exterior grade plywood. Extend each *Unistrut leg 36" min. below grade and embed each leg in a 12" diameter poured concrete footing. The concrete should not encase the service entrance conduit.

*Minimum Unistrut channel acceptable shall be hot dip galvanized 12 gauge steel 1-5/8" x 1-5/8" or PUD-approved equipment.

Alternate Construction:

2" hot dip galvanized steel angle iron or 2" hot dip galvanized rigid steel pipe with a hot dip galvanized pipe cap embedded in a 12" diameter poured concrete footing, or two fully pressure treated 6" x 6" x 10' wood post set 36" min. below grade and backfilled with gravel to facilitate drainage.

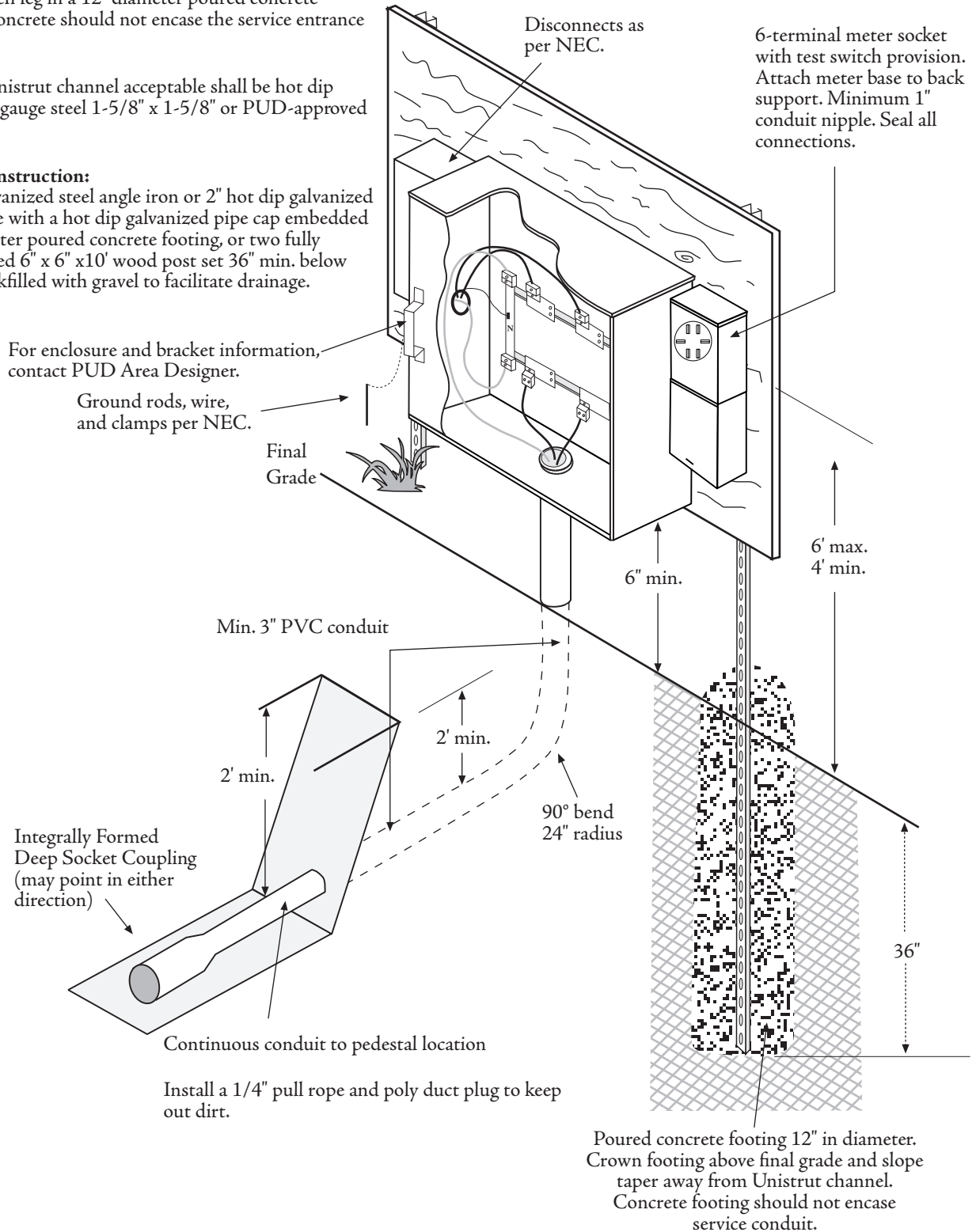

CONVERSIONS, OVERHEAD TO UNDERGROUND

1. In general, overhead to underground service conversion requires individual attention on specific requirements. Contact your PUD Area Designer for specific requirements and fees.

Note: The NEC requires that, where necessary, existing breakers, switches, panels, etc. must be upgraded to present requirements. Contact the Department of Labor and Industries - Electrical Division or your local electrical inspecting authority for specifics.

2. The underground service equipment installation shall comply with PUD requirements for a new service.
 - a. An underground riser conduit may be extended up to match the height of the existing overhead mast. This new riser must be within 18 inches of the existing mast. Refer to Figure 4-11.

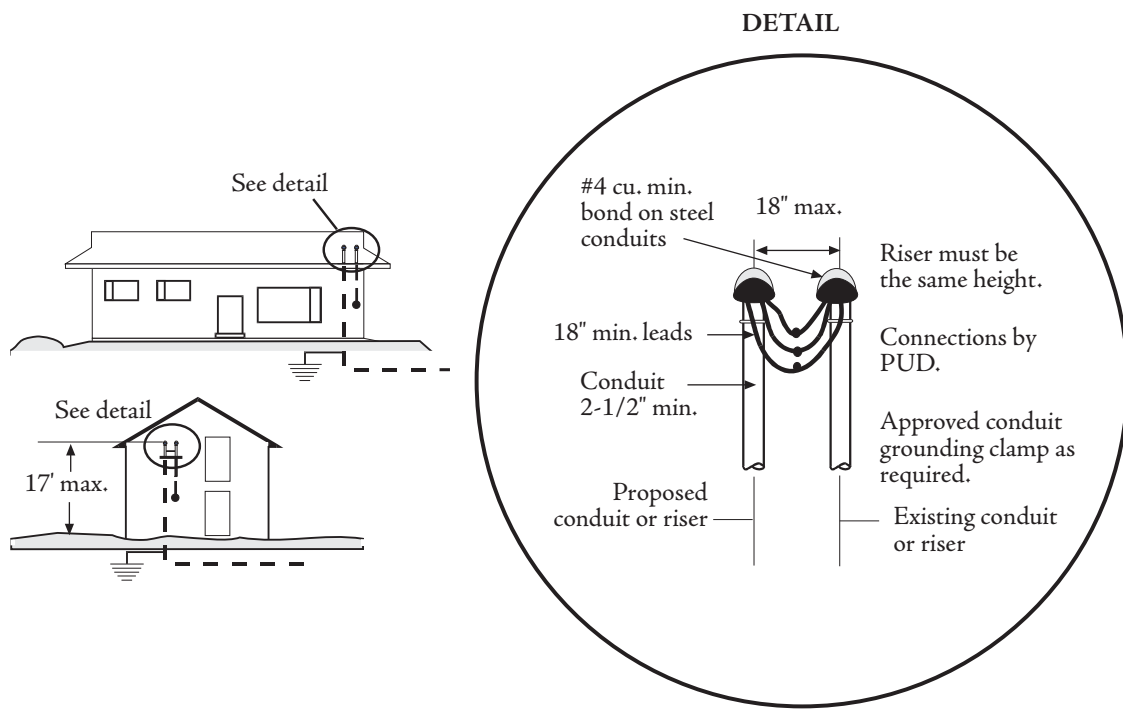

Figure 4-11

- b. Existing 200 amp surface-mounted meter bases, may be converted by installing an underground service riser conduit into the bottom of the meter base for installation of new underground service conductors. Refer to Figure 4-12.

Exceptions: The following conditions must apply:

- 1) Conduit must enter to one side of the bottom, not the center.
- 2) Meter base must be a minimum size of 10½" wide, 14" tall and 4" deep.

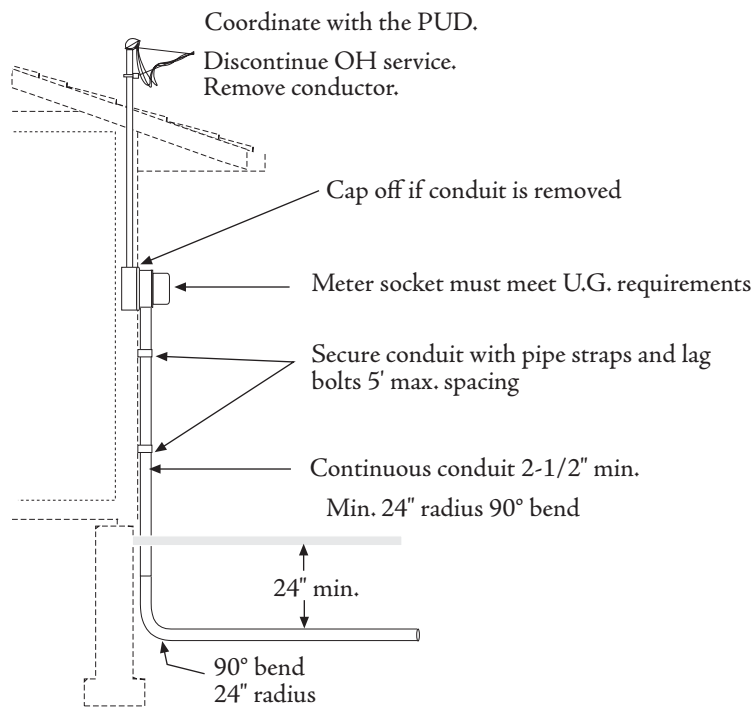

Figure 4-12

PRIMARY SERVICE (7200 volts) - RESIDENTIAL SYSTEMS ON PRIVATE PROPERTY

1. The customer shall prepare the vault site, provide easements, trenching and conduits
2. The PUD will install, own and maintain the vault, grounds, secondary handhole and secondary service conductors.
3. All trenching, backfilling and restoration work on private property shall be done by the customer.
4. The minimum cover required for primary is 36". The maximum cover for primary conductor shall be 47".
5. The minimum separation between electric and gas shall be 12 inches. The gas line shall be staked or shaded with backfill every 10 feet or as required to maintain separation. The minimum separation between electric and water/sewer shall be 36". Refer to Figure 4-1A.
6. Backfill containing large rock or paving material, cinders, large or sharply angular substance, or corrosive material shall not be placed in an excavation where materials may damage conduits, cables or other substructures or prevent adequate compaction of fill or contribute to corrosion of conduits, cables or other substructures (NEC 300-5).
7. The customer shall backfill within 24 hours after PUD inspection and before conductors are installed.
8. Conduits terminating in a handhole or vault shall have protective bushings on steel conduits. PVC conduit shall extend 5 inches into the vault and be temporarily sealed with a tapered, manufactured poly conduit plug. The PUD will install all bell ends on PVC conduit entering vaults, for primary conductors.
 - a. The customer shall prepare the vault site in accordance with Figure 4-13.
 - b. The PUD will provide and install the vault, ground rods, ground wire and secondary service pedestal.
 - c. The vault hole shall be plumb, level and square.
 - d. The customer shall install both the primary and the secondary conduits, pull ropes, seal all ends with a tapered, manufactured poly conduit plug to keep out dirt.
 - e. After inspection and approval, the customer shall backfill the trenches prior to the installation of the electrical system.

9. Primary Conduits in Trenches

- a. Conduit is required for all primary conductors on private property. All bends shall be long radius fiberglass or rigid steel electrical conduit. A maximum of 180° of bends shall be allowed. Exception: Naturally formed long sweeps of PVC conduit of 1° to 90° will be allowed.
 - 1.) PVC Conduit shall not be mechanically heated to form any sweep (bend).
 - 2.) Conduit shall not be placed in the trench to form a long sweep prior to the setup of cement in all joints involved. Cement setup time shall be per the manufacturer recommendations.
- b. Primary conduit sizes shall be 2 inches for single phase.
- c. The customer shall install a continuous length of knot-free ¼-inch polypropylene pull rope or Herculine P1250W ½-inch polyester pull tape with a 2-foot tail at each end and a tapered, manufactured poly conduit plug (do not use duct tape) at each end for all primary conduit(s), including future conduit(s), regardless of length of run.

Primary Distribution Trench With Joint Utilities

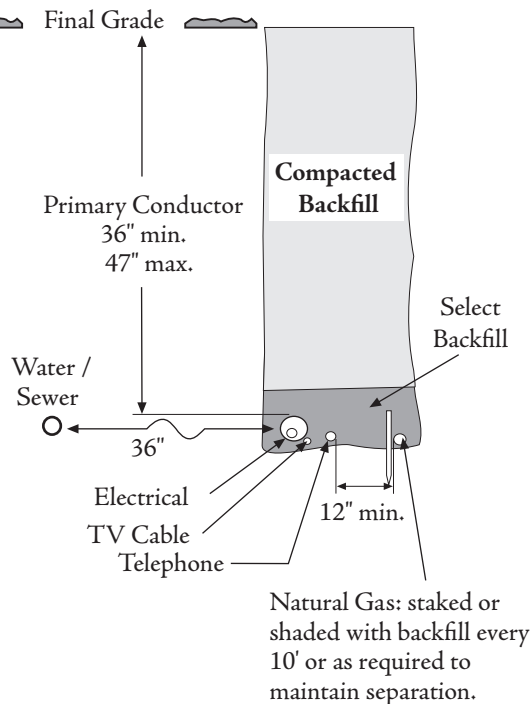

Figure 4-1A

The following information shall be imprinted on all PVC conduits:

1. Manufacturer's name or trademark
2. Nominal size
3. Material (PVC)
4. Utility duct and Standards (specification) number
5. DB (direct buried)

2", shall be gray and meet or exceed the requirements of any one of the following standards:

1. NEMA TC-2 (Schedule 40 or 80)

All conduit bends shall be 24" long radius type.

Note: Primary conduit bends shall be fiberglass or rigid steel electrical conduit.

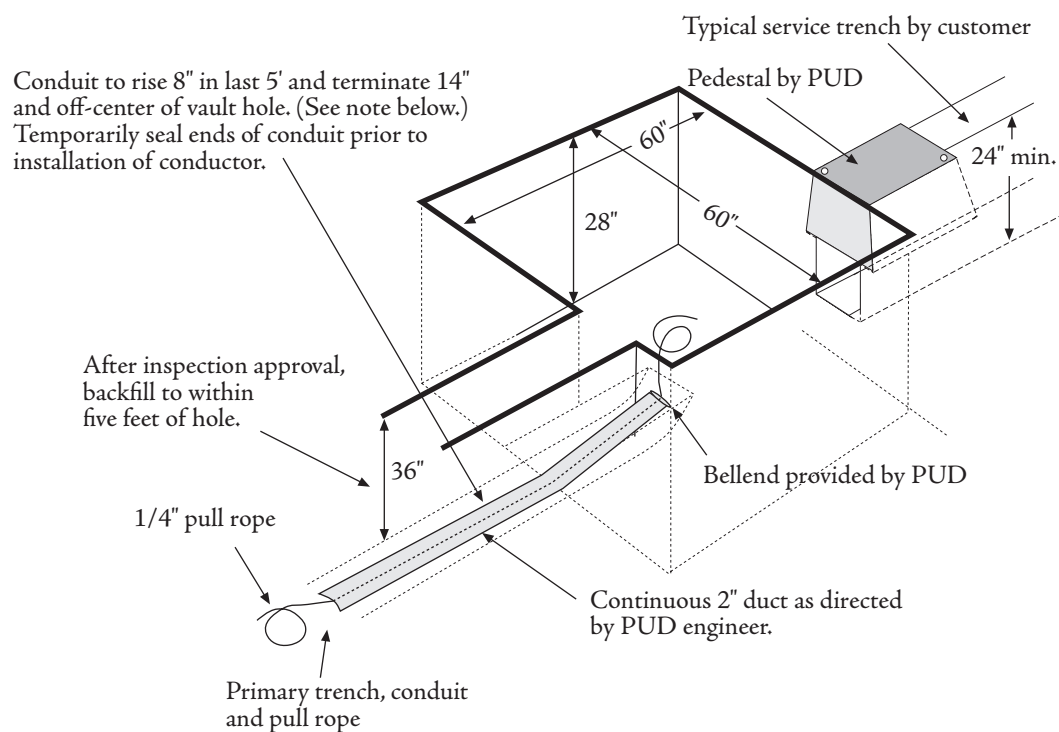

Conduit to rise 8" in last 5' and terminate 14" and off-center of vault hole. (See note below.) Temporarily seal ends of conduit prior to installation of conductor.

After inspection approval, backfill to within five feet of hole.

1/4" pull rope

Primary trench, conduit and pull rope

Typical service trench by customer

Pedestal by PUD

60"

28"

60"

24" min.

Bellend provided by PUD

Continuous 2" duct as directed by PUD engineer.

NOTE:

Primary trench and conduit to enter front of vault site and off-center to allow alignment of conduit with mouse holes in vault.

Figure 4-13



Call two (2) full working days before you dig!

**It's a required by law,
and you could be held liable for any
damages you incur to utility services**



Call 811 or 1-800-424-5555

At no charge to you, **UTILITIES UNDERGROUND LOCATION CENTER (DIAL DIG)** will mark where power, gas lines, and other utilities are located on your property, using the following color codes:

RED	Electric
YELLOW	Gas – Oil
ORANGE.....	Telephone – CATV
BLUE.....	Water
GREEN.....	Sewer
PURPLE	Reclaimed Water
PINK.....	Survey
WHITE.....	Proposed excavation



PO Box 1107
Everett WA 98206-1107

425-783-8272

snopud.com